

SR-i20E

I-STUD EVOLUTION SR-i20E
YOUR SAFETY EYES

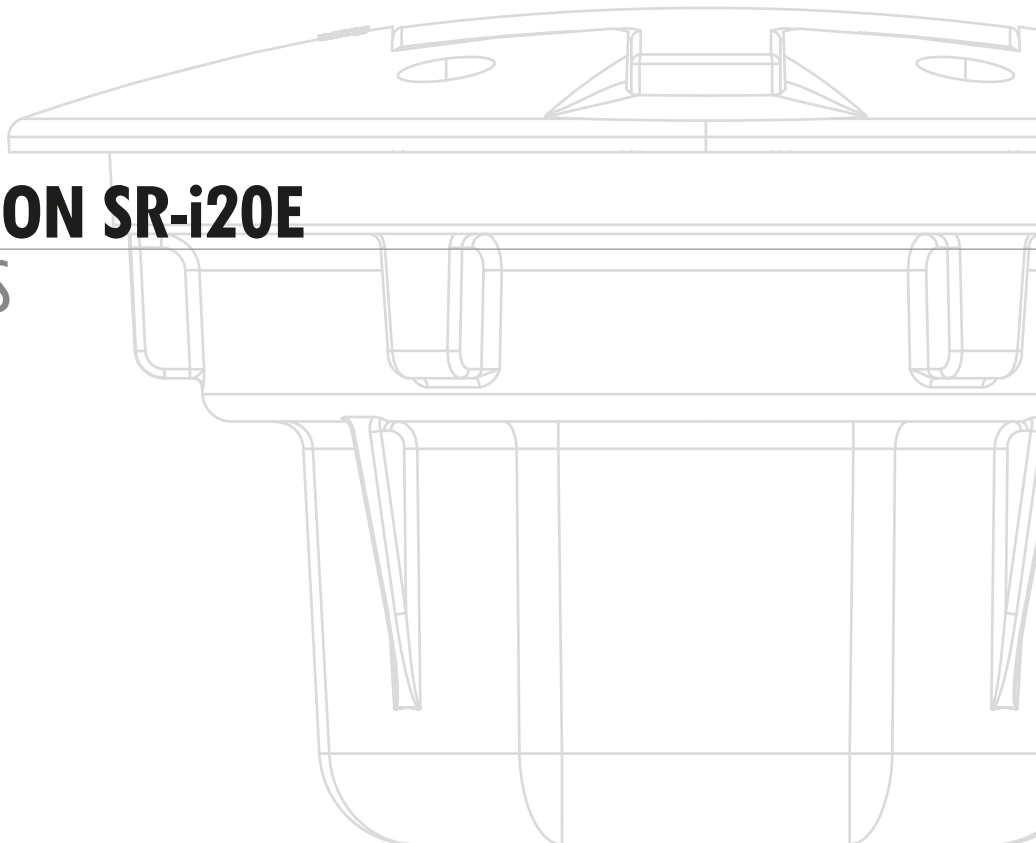

SR-i20E



I-STUD EVOLUTION SR-i20E

i-stud evolution technology applied to **SR-i20E** increase the performance of solar power studs with energy storage by battery or capacitor. The main advantage of i-stud evolution is the use of microcontroller technology inside each stud, which allows several beneficial features and control options.

KEY FEATURES:

Wake Up/Sleep Function

Allows the stud to stay in "sleep" mode before the application, extending the autonomy of the battery

Automatic Brightness Control

Manages the energy stored, adapt the brightness and regulate its light level in accordance with the energy charged during the day

Definition of the Working Period

Set up the number of hours the i-stud should work after night detection, when roads studs do not have to operate all night long

Operation Mode Flash/Always ON

Switch the stud's mode from 'flashing' to 'always on' and vice versa after installation

Flash Rate

Adaptation of the flash rate after installation

Night Level Detection

Adjustment of the lighting level detection (Lux)

Operation Mode Uni or Bi-directional

Modify the light direction temporarily or permanently

Low Temperature

Detects the possibility of ice forming on roads and change the LEDs colour to warn drivers about the dangerous weather condition

Log File

If a problem with the stud is detected the unit is able to make an internal log to discover what are the causes of the problem

SPECIFICATIONS:

OPTICAL

LEDs Number: 1 or 2 LEDs (uni-directional), 2 or 4 LEDs (bi-directional) - 5mm

LEDs Colour: Amber, Red, White, Blue, Green

MECHANICAL

Dimensions: Ø144mm x 87mm

Weight: 1Kg

Projection: 15mm

Minimum Installation Depth: 80mm

Material: Aluminium, Polycarbonate

Mechanical Resistance: 20 Tons

Protection Index: IP68 and IK10

STANDARD VERSION

Non programmable stud with basic functions

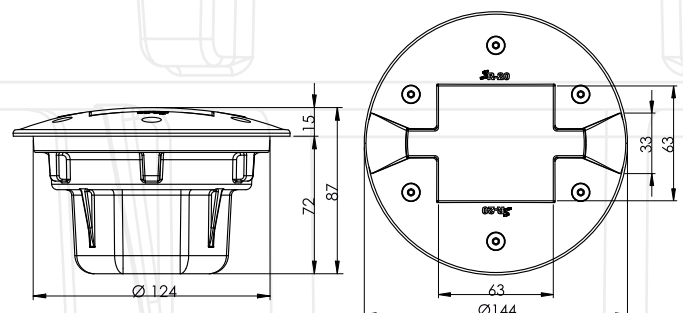

Dimensions: mm