



*Paving Intelligence into
Safety, Security & Mobility*



XCam-i™

**Automatic Incident Detection and
Congestion Video-Based Sensor**

Citilog's XCam-i is a field-deployable video sensor for traffic Automatic Incident Detection (AID) and congestion warnings. The video sensor is an ideal solution for enhancing new and existing closed-circuit television (CCTV) deployments. XCam-i provides a method to expand or enhance CCTV deployments with a low-cost option to maximize field-of-view coverage at all moments.

Pan-Tilt-Zoom CCTV cameras often change views, potentially leaving exposed areas lacking coverage. XCam-i allows CCTV cameras to maintain their presence at their primary viewpoints because XCam-i can be deployed to cover secondary views in a low-cost fashion. XCam-i can also serve as an ideal solution to deploy in remote areas where power and communications infrastructures are limited or unavailable thus providing a truly low-cost way to expand AID to remote areas. The XCam-i is a valuable asset for applications such as: hard shoulder monitoring, dynamic emergency lane and work zone monitoring. It enhances the performance of highway patrols on sensitive stretches of road.

XCam-i provides AID and congestion indication in real time on roadways (highways, expressways, etc.) through video image processing to enable truly automated surveillance that greatly increases the ability for rapid responses. Thus, XCam-i is ideal for traffic operations centers to improve road safety, security and mobility. At the operations center, XCam-i enables triggered alarms and on-screen highlighting (audible and visual) of incidents within a few short seconds after the occurrence.

With ultra-low power consumption and integrated wireless communications, the XCam-i video-sensor is especially designed to ease the deployment of AID on roadways where access to power and a communications infrastructure can be an issue.

XCam-i components (particularly the CMOS sensor) have been especially designed to ensure durability of the sensor and to optimize performance of the video-detection algorithm. The XCam-i is also a low cost sensor that makes the most of the infrastructure and its components for a quick return on investment (ROI) and an excellent cost/benefit ratio. Overall, the XCam-i sensor allows a more cost effective deployment of AID technology along any type of roadway – whether it is to be dense with cameras or it is a roadway with little to no access to power or a communications infrastructure.



KEY CAPABILITIES

- Automate traffic monitoring operations with real-time intelligent Automatic Incident Detection.
- Low power consumption and wireless communications for easy and flexible (dense area or remote roads) deployment and integration.
- Seamless integration into existing (legacy) Citilog AID systems and any ITS architecture.
- Easy communications of XCam-i sensor with any Supervision, SCADA or 3rd party system via an open protocol.

KEY BENEFITS

- Low cost method to enhance CCTV coverage and seamless deployment of AID to remote areas.
- Fast ROI (Return on investment).
- Reduce the negative economic, social and environmental impact from traffic incidents.
- Improve infrastructure and Traffic Operations Center efficiency.
- Reduce incident detection times thus, reducing response times and improving safety, security and mobility.

The XCam-i enables digital recording files permitting rapid identification of the incident. It includes a database for video clips of incidents. The digital video database of incident sequences provides a true account and record of road incidents.



System setup and modification of monitoring areas is performed with a few mouse clicks thanks to the friendly graphical user interface (GUI). The system allows configuration with multiple sets of parameters for each lane. Alarms can be triggered on one or several traffic lanes or across a group of cameras.

Maintenance tools enable identification of malfunctioning cameras and access to remote maintenance features. A Log Manager displays messages generated by the system and stores actions performed by operators, administrators and external systems.

The XCam-i provides a cost-effective, easy-to-integrate solution for wide or remote deployments of Automatic Incident Detection.

Technical Specifications

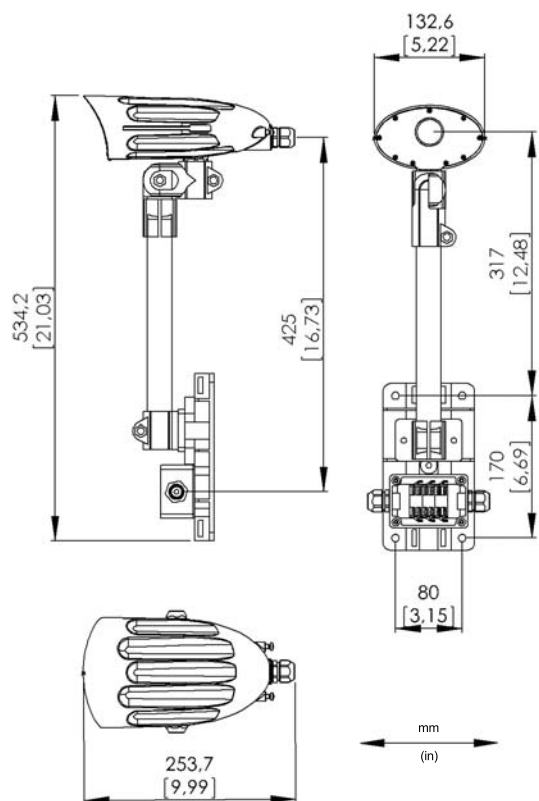

Sensor

- 1/4" VGA CMOS sensor.
- Minimum illumination 0.04 lux. @ f/1.2.
- Anti-blooming, zero smearing.
- Signal to Noise ratio: >50dB.

Housing

- IP67 Injection molded polycarbonate housing.
- Sun shield for hot climate and direct sun exposure.
- Size: 132 x 254 x 124 mm.

Hardware

- Power Supply: +12/24V AC/DC.
- Power consumption: < 3W.
- -34°C / +74°C.
- Humidity: 0 to 95% RH, non condensing.
- Weight: 600 g.

Communications

- Communication to a Citilog Server or to a third party Supervision software.
- Standard Software Developer's Kit.
- Ethernet.
- Serial RS-485.
- Wireless module (GPRS).

Latest Hardware specifications available upon request

DETECTION HIGHLIGHTS

- Trajectory and tracking-based stopped vehicles detection.
- Discriminates fluid traffic from congested traffic for enhanced stopped vehicles alarm notification and management.
- Threshold-based traffic slow-down and congestion detection.
- Video streaming and recording capability.

APPLICATIONS

- Hard shoulder monitoring for dynamic emergency lanes.
- Work zone monitoring.
- Sensitive stretches of road.
- Highway patrols performance enhancement.



www.citilog.com

NORTH AMERICA

2 Bala Plaza, Suite 300
Bala Cynwyd, PA 19004 - USA
Tél: +1 (215) 609-4945
Fax: +1 (484) 873-2292
citilogusa@citilog.com

EUROPE, MEA & AFRICA

19/21, rue du 8 mai 1945
94110 Arcueil - France
Tél: +33 1 41 24 34 54
Fax: +33 1 41 24 34 99
citilog@citilog.com

SPAIN, PORTUGAL & SOUTH AMERICA

C/.Marina Baixa 3, Esc.1 Pta.2
E46015 Valencia - Spain
Tél: +34 667 659 063
Fax: +33 1 41 24 34 99
espana@citilog.com

ASIA PACIFIC

35/F Central Plaza
18 Harbour Road
Wanchai Hong Kong
Tél: +852 2593 1500
Fax: +852 2593 1222
citilog@citilog.com